

JS-500-HD

PRO-SERIES

Dual Axis Contact Joystick With Single 10K Potentiometer + 1/2 NPT Adaptor



Product shown without cable harness for clarity

GENERAL DIMENSIONS

-X



1/2 NPT

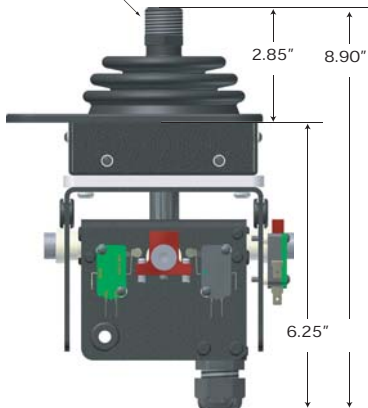

Product shown without switches for clarity

Control Unit Features:

- Contact Rating: 16 Amps@125/250 vAC
- Standard Wiring N.O.
- 16 ± 2 Degrees (On X/Y Axis) From Center
- 10lbs @ Contact (On X/Y Axis)
- 10K, 3 Watt Potentiometer
- Std 1/2 NPT Mounting Thread
- 4 Ft Cable Harness
- Protective Boot Seal
- Heavy Duty Construction

PRO-SERIES JOYSTICK

CTI PART#: CTI-2021460

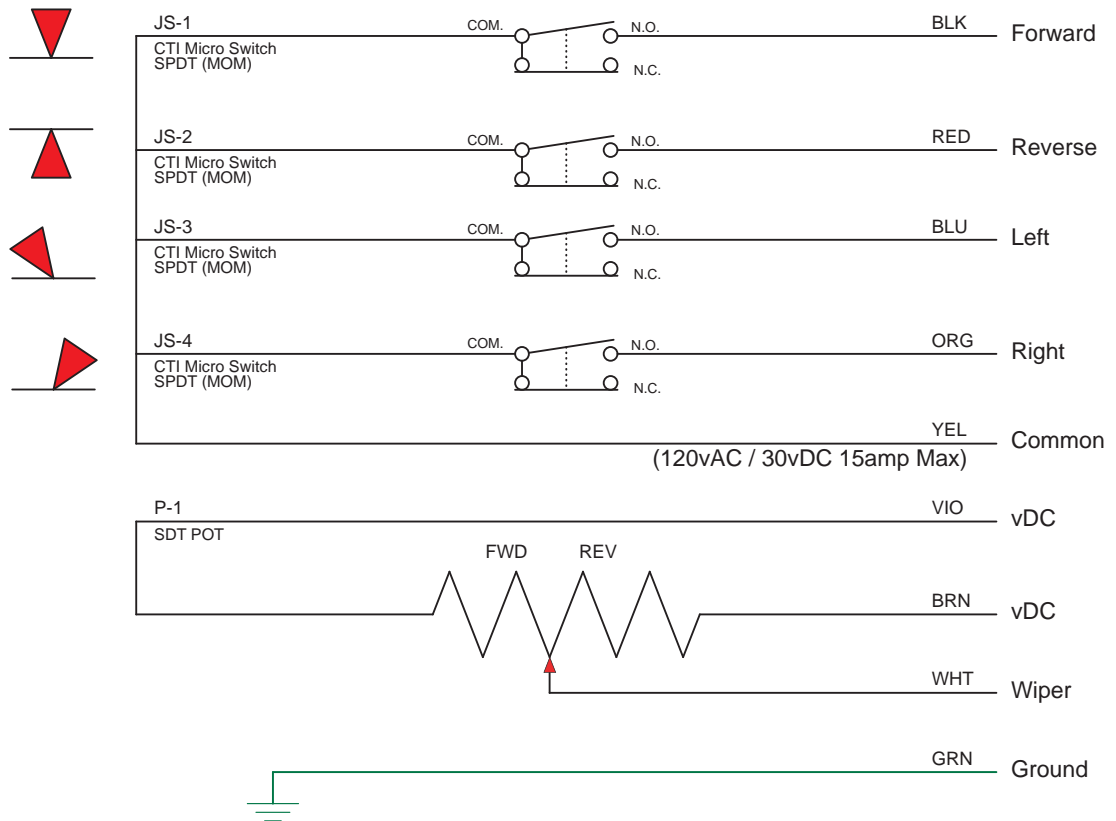

Spare Replacement Components For Part

CTI-2021460

Cable Harness: 22-C-NQ1520-J-4

Protective Boot: 33-BSB-970014-01

Control Stick: 71-933020-01

Adaptor: 28-040039-01

Boot Seal Plate: 65-A02132-03

Fwd/Rev Switch: 32-S-V3L-G-3003-D8

Adjustable Cam: 63-970200-03

Lt/Rt Switch: 32-S-V3L-G-3003-D8

10K Potentiometer: 46-P-53C3-10K

